

Fatty Acid Oxidation Is Preserved Regardless of Impaired Uptake in the Chronically Failing Rat Heart

Hitoshi TACHIKAWA

First Department of Internal Medicine, Radioisotope Center, Niigata University Graduate School of Medicine; Department of Clinical Pharmacology, Niigata College of Pharmacy, Niigata, Japan

Received December 25 2003; accepted January 15 2004

Summary. Fatty acid is used as a major fuel in the fasting heart, but the precise metabolism in the failing heart remains unknown. We assessed the hypothesis that the fatty acid metabolism might be impaired or delayed during heart failure. We examined in vivo kinetics of an isotope-labeled fatty acid analogue and its substrates as well as hemodynamic parameters and histopathological findings in a rat model of postmyocarditic dilated cardiomyopathy. Rat experimental autoimmune myocarditis (EAM) was induced by injection with porcine cardiac myosin. Rats were treated with quinapril, an angiotensin-converting enzyme inhibitor or vehicle, from the 28th day after healing of myocarditis until the 60th day. On the 61st day, or the compensated chronic heart failure phase, rats were injected with β -methyl-iodophenylpentadecanoic acid (BMIPP) and 15-(*p*-iodophenyl)-9-methylpentadecanoic acid ($[^{125}\text{I}]$ 9MPA), then sacrificed 3, 10, 30, and 60 min later. The hearts were excised, their radioactivities were calculated, and the homogenates were assayed quantitatively on thin layer chromatography. Left ventricular weight was found to increase by 1.6-times and the myocardial area of fibrosis was prominent in chronic heart failure rats. Myocardial uptake of BMIPP and 9MPA decreased by 48~75% in the failing heart; however, the final oxidized product ratio of total 9MPA substrates, *p*-iodophenylacetic acid (PIPA), increased by 127~136% compared with the normal heart. Quinapril decreased the central venous pressure and left ventricular end-diastolic pressure, but increased the absolute value of the rate of isovolumetric contraction. Quinapril suppressed left ventricular hypertrophy by 70% and decreased the fibrosis area by 35% in this model. Quinapril also improved the initial uptake of fatty acid into the myocardium, but it did not affect the substrate pattern

of 9MPA metabolites. Our findings suggest that fatty acid oxidation is preserved regardless of impaired uptake in the chronically failing rat heart and that quinapril is able to correct the uptake of fatty acid into the myocardium.

Key words—cardiomyopathy, fatty acid, β oxidation, BMIPP.

INTRODUCTION

The heart uses free fatty acid (FFA) in the fasted state and carbohydrates in the fed state as its major energy source.^{1,2,3)} The uptake of each substrate by the heart is partly dependent on blood concentrations and energy demand. Substances for energy production change under various pathological conditions.⁴⁾ The heart predominantly uses fatty acid during ischemia,⁵⁾ and has been suggested that the heart uses carbohydrate preferentially during heart failure.^{6,7)} Recent reports suggest that an impaired fatty acid metabolism leads to the accumulation of fatty acid derivatives, which may be attributed to cardiac hypertrophy.^{8,9)} However, the precise kinetics of FFA in vivo remains unknown in chronic heart failure.

β -methyl-iodophenylpentadecanoic acid (BMIPP) is commonly used to assess cardiac fatty acid metabolism.^{10,11)} After venous injection, BMIPP enters the cardiomyocyte with thioesterification. A part of BMIPP is stored as tissue triglyceride while the majority is transferred from the cytoplasm to the

Correspondence: Hitoshi Tachikawa, First Department of Internal Medicine, Niigata University Graduate School of Medicine, Asahimachi 1-754, Niigata 951-8510, Japan.

Abbreviations—BMIPP, β -methyl-iodophenylpentadecanoic acid; 9MPA, 9-methylpentadecanoic acid; 3MNA, 3-methylnonanoic acid; PIPA, *p*-iodophenylacetic acid.

mitochondria through a carnitine shuttle by a staged transfer system that requires the formation of fatty acid acyl-CoA. Intramitochondrial BMIPP-CoA converts directly to PIPA-CoA through 6-fold β oxidation after α oxidation and decarboxylation.¹⁰ The 15-(p-iodophenyl)-9-methylpentadecanoic acid ($[^{125}\text{I}]$ 9MPA) is a modified long chain (15 carbons, C15) fatty acid which has a methyl branch like BMIPP. The 9MPA-CoA that enters the mitochondria is initially converted into 3-methylnonanoic acid (3MNA)-CoA. Continuously, 3MNA-CoA changes fatty acyl-CoA again through α oxidation and decarboxylation. Then additional β oxidation yields the final metabolite, p-iodophenylacetic acid (PIPA)-CoA (Fig. 2). Accordingly, 9MPA is suitable for evaluating the abilities of fatty acid uptake and the kinetics of β oxidation in vivo.^{12,13,14} We previously studied the kinetics of isotope-labeled fatty acid analogue and its metabolites in the hearts of peroxisome proliferator-activated receptor α (PPAR α) knockout mice.¹²

Myocarditis has been given as a possible cause of dilated cardiomyopathy.¹⁵ We previously developed an experimental autoimmune myocarditis (EAM) model in rats which can serve as a model of human giant cell myocarditis.¹⁶ After the acute phase of myocarditis, there is progressive dilatation of the left ventricle and deterioration in contractility which ultimately leads to dilated cardiomyopathy.¹⁷ Angiotensin converting enzyme (ACE) inhibitors have shown extensive evidence in preventing left ventricular remodeling and have favorable long-term effects on morbidity and mortality.^{18,19} We have reported the efficacy of ACE inhibitors using this model.²⁰ The purpose of the present study was to elucidate the kinetics of FFA metabolism using this rat model of chronic heart failure.

MATERIALS AND METHODS

Experimental animals

Male Lewis rats (8 weeks old) were purchased from Charles River, Japan (Yokohama, Japan) and maintained in our facilities. Rat experimental autoimmune myocarditis (EAM) was induced by immunization with purified pig cardiac myosin as previously described.¹⁶ Rats surviving 28 days after immunization were randomly assigned to receive either the vehicle (methylcellulose 0.5 mL) or therapy with the angiotensin-converting enzyme inhibitor (quinapril 2 mg/kg). All rats were treated by daily oral administration until the 60th day. The study protocol was approved by the Guidelines on Animal Experimentation at our institute.

Hemodynamic measurements

On the 60th day, rats were anesthetized with 0.5% halothane mixed with 100% oxygen, and systemic and left ventricular hemodynamic parameters were recorded as described previously.^{20,21}

Kinetics of fatty acids metabolism in vivo

On the 61–63rd days, ^{125}I -BMIPP (0.7 MBq) or ^{125}I -9MPA (1.0 MBq) was intravenously injected into rats after fasting for at least 24 hours. At 3, 10, 30 and 60 min after injection, the rats were sacrificed. The hearts were excised and pericardium and atrial tissue were removed. The ventricle was weighed and then cut into three parts. The left apical ventricle was quickly excised and stored in a gamma counter tube, and its radioactivity was measured by a well-type scintillation counter (Aloka ARC-300, Tokyo, Japan). The cardiac uptake in each phase was presented as the differential absorption ratio: DAR = (radioactivity of the tissue)/(total injected radioactivity) \times (body weight)/(tissue weight).

Lipid extraction from cardiac tissue was performed according to the modified method developed by Folch et al.²² Briefly, a part of the heart tissue was homogenized in 2N HCl and extracted twice with chloroform/methanol (2 : 1, v/v). The organic, aqueous, and solid phase substances were separated. Individual radioactivity of ^{125}I -labeled 9MPA, 3MNA, PIPA and triglyceride in the organic phase was assayed by thin-layer chromatography (TLC) on a reversed phase plate (C18 Silicagel Spotfilm; Tokyo Kasei Kogyo Co. Ltd., Tokyo, Japan), together with ^{125}I -labeled standard fatty acids (9MPA, 3MNA, and PIPA). Each of these long chain fatty acids and their fatty acyl CoA (9MPA-CoA, 3MNA-CoA, and PIPA-CoA) can be detected in the same partition on the TLC separation. The origin partition includes triglyceride. Because the absolute dose of the product may be affected by the uptake of total 9MPA substrate, the ratios (%) of each catabolized product of total 9MPA substrates are calculated quantitatively by an NIH image from the TLC separation image in order to assess the metabolic turnover of the steps of 9MPA metabolism.

Histological examination

The mid-ventricle was cut into 2 mm transverse slices, fixed in 10% formalin, embedded in paraffin, sliced, and stained by the Azan-Mallory method. Myocardial fibrosis was assessed as the ratio of the fibrosis area to the whole area of the section as

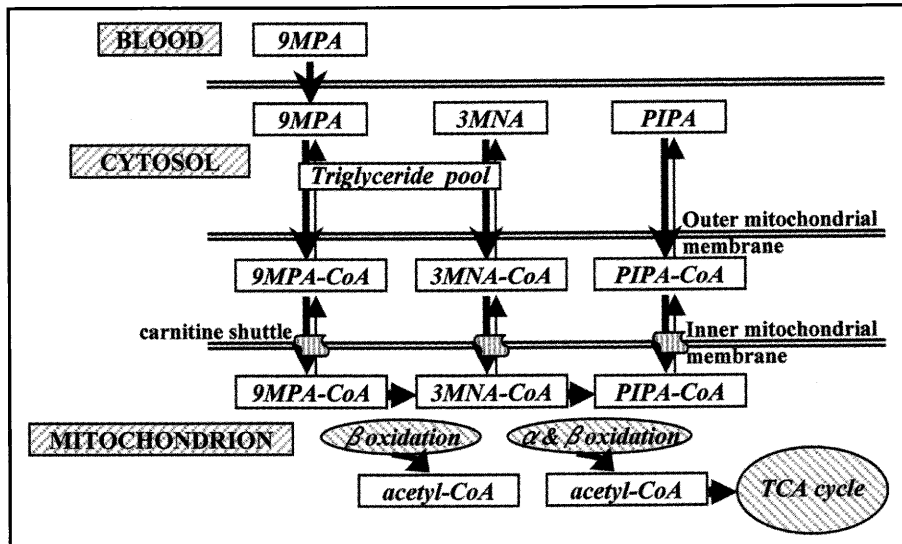

Fig. 1. Scheme of the metabolic pathway of 9-methylpentadecanoic acid (9MPA). 9MPA enters a cardiomyocyte with thioesterification, and a part of 9MPA is stored as tissue triglyceride. The majority of 9MPA is transferred from the cytosol to the mitochondria by a staged transfer system that requires the formation of acyl carnitine. Thereafter, mitochondrial 9MPA-CoA is oxidized and converted to 3-methylnonanoic acid (3MNA)-CoA. Simultaneously, 3MNA-CoA is oxidized and decarboxylated. Then additional β oxidation yields the final metabolite, p-iodophenylacetic acid (PIPA)-CoA.

described previously,²⁰⁻²¹ using a color image analyzer (Mac Scope, MITANI co., Fukui, Japan).

Statistical analysis

Results were presented as mean \pm SEM. Statistical significance was determined by 1-way ANOVA followed by the Fisher's Protected Least Significant Difference Method. Statistical significance was assumed at an alpha value of .05.

RESULTS

Left ventricular remodeling

The ventricular weight was considerable in the rats with chronic heart failure, and ventricular weight correlated with body weight (VW/BW) was higher in these rats compared with normal control rats (Table 1). The myocardial fibrosis area was also increased in rats with chronic heart failure (Fig. 3).

Cardiac Function

Hemodynamic parameters are shown in Table 2. Systemic arterial pressure decreased and central venous pressure and left ventricular end-diastolic

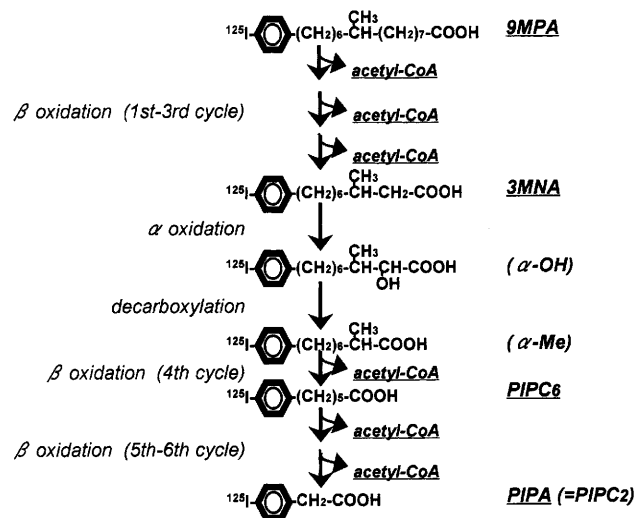

Fig. 2. β oxidation of 9-methylpentadecanoic acid (9MPA). 9MPA is oxidized for 3 cycles to convert into 3-methylnonanoic acid (3MNA). Consequently, 3MNA is metabolized again through α oxidation and decarboxylation. Then additional β oxidation for 3 cycles yields the final metabolite, p-iodophenylacetic acid (PIPA).

Table 1. Ventricular weight and myocardial fibrosis

| | Ventricular weight (g) | Ventricular weight (g) /Body weight (kg) | Myocardial fibrosis (%) |
|-----|------------------------|---|-------------------------|
| NC | 0.89±0.02 | 0.267±0.008 | 2±1 |
| CHF | 1.44±0.04* | 0.436±0.016* | 29±5* |
| Tx | 1.00±0.05* | 0.33±0.017* | 19±7† |

Values are mean±SE. NC, normal control; CHF, chronic heart failure; Tx, Therapy with quinapril. * $P < .0001$ vs NC. † $P < .01$ vs CHF.

Table 2. Hemodynamic parameters

| | Normal control (n=4) | CHF (n=8) | Tx (n=8) |
|---|-------------------------|--------------|-------------------------|
| Heart rate (beats per minute) | 314.4±22.6 | 307.2±23.2 | 245.0±15.3 [§] |
| Mean arterial pressure (mm Hg) | 98.3±6.5 | 57.4±4.8* | 40.7±3.6 [§] |
| Left ventricular pressure (mm Hg) | 90.4±5.5 | 68.7±2.5† | 57.7±3.1 |
| Central venous pressure (mm Hg) | 1.2±0.2 | 5.6±1.1† | 2.4±0.6 [§] |
| Left ventricular end-diastolic pressure (mm Hg) | 7.6±1.6 | 18.9±3.5† | 7.4±2.3 [‡] |
| +dP/dt (mm Hg/s) | 3923±575.0 | 2409±252.5† | 3436±206.0 [§] |
| -dP/dt (mm Hg/s) | -4741±701.1 | -2488±445.1† | -3593±191.1 |

Values are mean±SE. Study groups as shown in Table 1. +dP/dt, rate of isovolumetric contraction; -dP/dt, rate of isovolumetric relaxation. * $P < .001$, † $P < .05$ vs Normal control, ‡ $P < .01$, § $P < .05$ vs CHF.

pressure increased in rats with chronic heart failure compared with normal control rats. The absolute values of the rate of isovolumetric contraction and relaxation were also lower in the former rats than the latter ones.

Myocardial uptake of fatty acid

Representative autoradiography images are shown in Fig. 4. The distribution of 9MPA was homogenous in normal rats. 9MPA accumulation decreased in proportion to myocardial damage and inhomogeneously in the rats with chronic heart failure.

The myocardial 9MPA uptake presented as the DAR of the rats with chronic heart failure was less in each phase compared with normal rats (Table 2). Compared with the uptake at 3 min (6.6±0.2 and 8.7±0.8, $P < .05$), those at 10 (5.3±0.4 and 8.7±0.4, $P < .0001$), 30 (3.5±0.4 and 7.0±0.7, $P < .0005$) and 60 min (2.9±0.2 and 5.6±0.5, $P < .0005$) of the rats with heart failure were markedly decreased. The uptake of BMIPP of rats with chronic heart failure was also less for each time compared with normal rats (5.6±0.2 and 9.5±0.7, $P < .005$ at 3 min, 4.2±0.2 and 7.1±1.0, $P < .01$ at 30 min, 2.5±0.4 and 4.5±0.9, $P < .005$ at 240 min).

Kinetics of fatty acid metabolism in vivo

Representative TLC samples are shown in Fig. 5, and the values are presented in Table 3 and Fig. 6. The ratio of the triglyceride pool did not differ in each phase between rats with chronic heart failure and the control rats. The ratio of 9MPA was also not different in each phase between the two groups. The 3MNA ratio was higher by 141% in rats with heart failure at 3 min; however, the ratio decreased remarkably according to time. The PIPA ratio was higher by 160% at 60 min in the experimental rats compared with normal rats. The ratio of 3MNA+PIPA was higher by 127~136% at 3, 10, and 60 min in the former rats compared with the controls (Fig. 6).

Effects of quinapril on cardiac function, left ventricular remodeling and fatty acid metabolism in vivo

Quinapril reduced ventricular weight, VW/BW, and suppressed myocardial fibrosis in the rats with chronic heart failure (Table 1 and Fig. 3). Quinapril increased systemic arterial pressure and decreased central venous pressure and left ventricular end-diastolic pressure in those rats treated with the

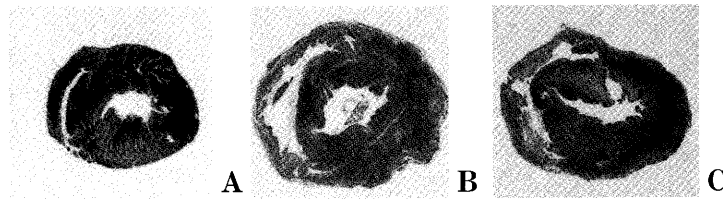

Fig. 3. Myocardial histopathological changes in rats with chronic heart failure: (A) normal control; (B) chronic heart failure; (C) chronic heart failure treated with quinapril. (Azan-Mallory stain, Original magnification $\times 2$)

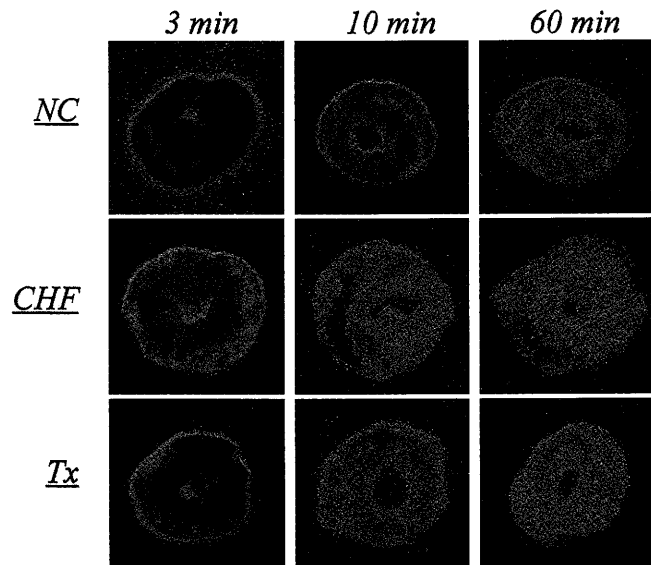

Fig. 4. Representative autoradiography images of cardiac 9MPA distribution. 9MPA distribution was homogenous in normal rats. 9MPA accumulation decreased in proportion to myocardial damage and also inhomogeneously in rats with chronic heart failure. NC, normal control; CHF, chronic heart failure; Tx, Therapy with quinapril.

vehicle (Table 2). The absolute value of the rate of isovolumetric contraction was also increased by quinapril treatment in rats with chronic heart failure. Regarding fatty acid metabolism, quinapril increased cardiac 9MPA uptake at 3 min and 60 min in these same rats. Quinapril had no effect on the ratio of fatty acid metabolites and the triglyceride pool (Table 2).

DISCUSSION

In this study, we examined the kinetics of myocardial fatty acid metabolism using isotope-labeled fatty acid and found that the turnover of fatty acid oxida-

tion in chronic heart failure was not impaired while the uptake of FFA was. The ratio of PIPA showed a higher level in the failing heart; nevertheless, the myocardial 9MPA uptake was reduced. The higher ratio of metabolic substrates suggests that 9MPA can be oxidized rapidly in the failing heart. Additionally, the ratio of 3MNA+PIPA increased in those rats with chronic heart failure compared with normal rats. The ratio of 3MNA+PIPA represents the turnover of the initial β oxidation alone, and does not depend on subsequent α oxidation and decarboxylation (Fig. 2). Quinapril suppressed left ventricular remodeling and improved cardiac function. Regarding the cardiac fatty acid metabolism, quinapril improved the myocardial uptake of FFA in proportion

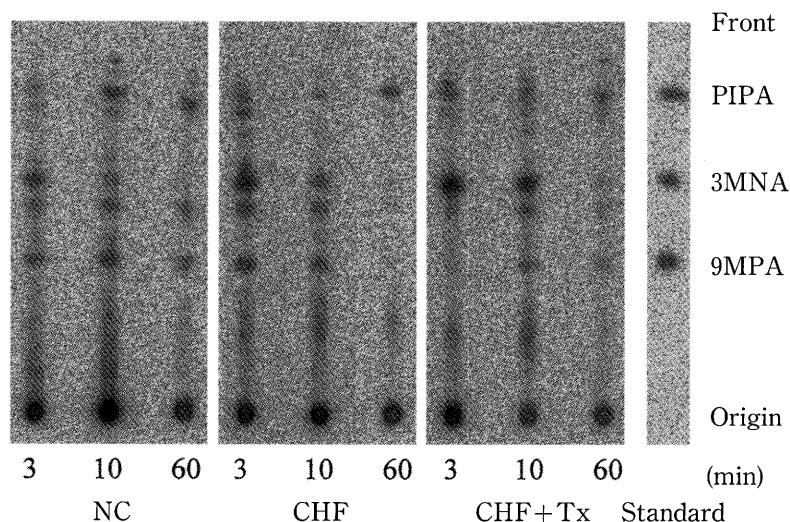

Fig. 5. Representative images of TLC separation of 9MPA metabolites. The 3MNA ratio was higher in rats with heart failure (CHF) at 3 min; however, the ratio decreased remarkably according to time. The PIPA ratio was higher at 60 min in rats with chronic heart failure compared with normal rats (NC). The ratio of 3MNA+PIPA was higher at 3, 10, and 60 min in rats with heart failure compared with normal rats. Quinapril (Tx) made no difference in the ratio of fatty acid metabolites and the triglyceride pool in rats with chronic heart failure.

Table 3. Quantitative analysis of 9 MPA uptake and metabolites

| | | 3 min | 10 min | 30 min | 60 min | Therapy with quinapril | | |
|--------------|-----|-----------|-----------|----------|-----------|------------------------|----------|----------|
| | | | | | | 3 min | 10 min | 60 min |
| DAR | NC | 8.7±0.8 | 8.7±0.4 | 7.0±0.7 | 5.6±0.5 | | | |
| | CHF | 6.6±0.2* | 5.3±0.4† | 3.5±0.4‡ | 2.9±0.2‡ | 8.9±1.5§ | 5.5±0.9 | 5.7±1.0§ |
| TG, % | NC | 28.1±1.6 | 25.7±2.0 | 24.7±2.6 | 26.1±1.6 | | | |
| | CHF | 23.0±1.3 | 30.2±1.9 | 25.9±7.2 | 26.5±3.7 | 29.7±2.2 | 32.9±1.9 | 31.1±3.7 |
| 9 MPA, % | NC | 6.3±0.8 | 4.1±0.3 | 3.9±0.7 | 5.7±0.8 | | | |
| | CHF | 4.7±0.4 | 3.6±0.3 | 3.9±1.1 | 4.3±0.1 | 5.2±1.1 | 4.7±0.8 | 4.3±0.7 |
| 3 MNA, % | NC | 11.3±2.0 | 4.9±0.7 | 3.4±0.4 | 4.1±0.6 | | | |
| | CHF | 16.1±1.1* | 7.3±0.7 | 3.9±1.3 | 3.3±0.5 | 17.5±2.3 | 5.1±0.4 | 2.9±0.4 |
| PIPA, % | NC | 5.4±0.8 | 9.3±0.7 | 11.2±1.5 | 10.5±1.2 | | | |
| | CHF | 6.1±1.2 | 12.0±1.0 | 14.6±2.9 | 16.8±1.2† | 4.5±1.3 | 10.8±0.7 | 13.1±0.6 |
| 3MNA+PIPA, % | NC | 16.8±2.0 | 14.2±1.1 | 14.6±1.6 | 14.7±1.1 | | | |
| | CHF | 22.3±1.6* | 19.4±1.4* | 18.6±3.2 | 20.1±1.4* | 22.0±3.1 | 16.0±0.9 | 16.0±1.1 |

Values are mean±SE. DAR, differential absorption rate; NC, normal control; CHF, chronic heart failure; Tx, Therapy with quinapril. * $P < .05$, † $P < .001$, ‡ $P < .005$, vs NC. § $P < .05$ vs CHF.

to the restoration of myocardial damage. However, it did not affect the turnover of fatty acid oxidation. One possible explanation is that the capacity of fatty

acid oxidation is constant in mitochondria, even in the failing heart. The utilization of FFA in the myocardium may depend on the uptake of FFA,

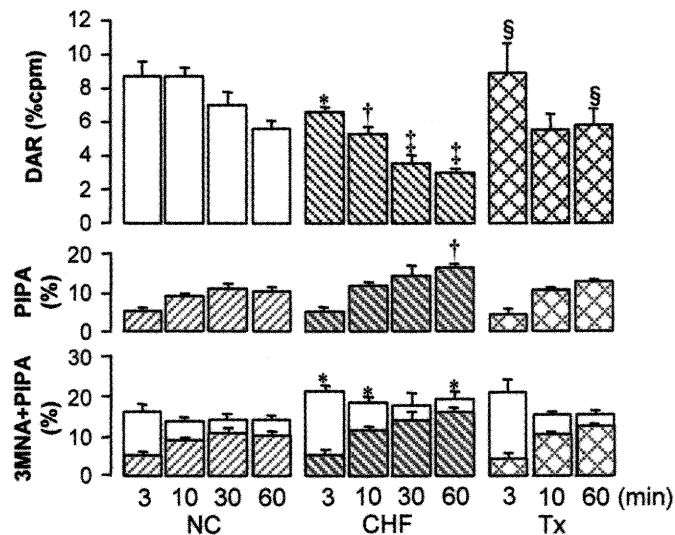

Fig. 6. Myocardial uptake of 9MPA (*above*) and the ratio of PIPA (*middle*) and 3MNA+PIPA (*bottom*) in normal rats (NC), rats with chronic heart failure (CHF), and rats with chronic heart failure treated by quinapril (Tx). * $P < .05$, † $P < .001$, ‡ $P < .005$, vs NC. § $P < .05$ vs CHF.

which is impaired in chronic heart failure.

In order to confirm our hypothesis, we also examined the expressions of transporters and enzymes involved in fatty acid metabolism in the myocardium. Contrary to our expectations, the failing heart showed decreased mRNA expressions of medium chain acyl-CoA dehydrogenase (MCAD), carnitine palmitoyl-CoA transferase II (CPT-II), and PPAR α . Mitochondrial β oxidation was also regulated by the levels of nicotinamide adenine dinucleotide (NAD $^+$) and flavin adenine dinucleotide (FAD). The decreased levels of NADH $_2^+$ and FADH $_2^+$ may stimulate the turnover of the whole fatty acid oxidation spiral during chronic heart failure,^{4,5,23} where the oxygen supply, respiratory quotient, and adrenergic activity may be important determinants of the kinetics of β oxidation.

Our present study showed that quinapril improved the initial uptake of fatty acid into the myocardium, but it did not affect the substrate pattern of 9MPA metabolites. ACE inhibitors are the most popular drugs for the management of chronic heart failure. ACE inhibitors decrease cardiac preload and afterload, reduce the progression of cardiac remodeling, and improve long-term survival.^{18,19} Some clinical studies showed that patients with heart failure treated with ACE inhibitors improved in their uptake of BMIPP and had a reduced washout rate.^{24,25} However, these studies -- the present one included --

cannot answer whether these effects were caused by the direct action of ACE inhibitors or an improvement of the heart failure. Several studies provide some possible explanation for these effects of ACE inhibitors. ACE inhibition improves insulin sensitivity by increased tissue bradykinin levels^{26,27,28} and enhanced insulin-stimulated glycogen synthesis.²⁹ Some experimental studies showed that angiotensin II enhanced lipid hydrolysis in the cardiomyocyte³⁰ and that the ACE-inhibitor decreased the serum level of nonesterified fatty acids. The decreased level of serum nonesterified fatty acids may contribute to an improvement of the insulin-resistant state and the oxidative capacity of the cell availability for glucose oxidation.^{31,32,33} The decreased level of nonesterified fatty acid contributes to enhanced tissue fatty acid esterification, which may increase the uptake to cardiomyocytes observed in the present study.

Several variables should be pointed out. Glucose oxidation may be increased in the failing heart in order to compensate for a lower use of fatty acid. However, we only assessed the kinetics of fatty acid metabolism because of technical limitations. There are few previous studies, and there is a discrepancy between clinical and experimental ones.^{34,35,36} The discrepancy may derive from different methods to quantify fatty acid metabolites, the severity of the heart failure, or the pharmacological treatment. Although our present study -- whose methods were

similar to clinical procedures -- showed the accelerated steps of fatty acid β oxidation in our model of dilated cardiomyopathy, we cannot answer how the energy products are attributed to the fatty acid metabolism. In order to answer this question, the quantification of acetyl CoA may be necessary.

In conclusion, the present study provides the first evidence of the kinetics of myocardial fatty acid oxidation. The turnover of fatty acid oxidation was preserved even in the failing heart, although the uptake of fatty acid was impaired. Therapy with the ACE inhibitor improved the uptake of fatty acid, but it did not affect the process of cardiac β oxidation.

Acknowledgments. This work was supported in part by a Grant for Research on Specific Diseases from the Ministry of Health, Labor, and Welfare.

I wish to thank Yoshifusa Aizama (First Department of Internal Medicine, Niigata University Graduate School of Medicine), Kenichi Watanabe (Department of Clinical Pharmacology, Niigata College of Pharmacy), Makoto Kodama (First Department of Internal Medicine, Niigata University Graduate School of Medicine), and Toshihiro Takahashi (Radioisotope Center, Niigata University Graduate School of Medicine) for their helpful support and discussion on this manuscript.

REFERENCES

- 1) Neely JR, Morgan HE: Relationship between carbohydrate and lipid metabolism and the energy balance of heart muscle. *Ann Rev Physiol* **36**: 413-459, 1974.
- 2) Randle PJ, Morgan HE: Regulation of glucose uptake by muscle. *Vitamines Horm* **20**: 199-249, 1962.
- 3) Opie LH: Metabolism of the heart in health and disease. Part I. *Am Heart J* **76**: 685-698, 1968.
- 4) Opie LH: Substrate and energy metabolism of the heart. In: Sperelakis N (ed). *Physiology and pathophysiology of the heart*. Boston: Kluwer Academic, 1989, p 327-359.
- 5) Opie LH: Fuels: Aerobic and Anaerobic Metabolism. In: *The Heart. Physiology, from cell to circulation*. Third edition. Lippincott-Raven Publishers, 1997, p 295-342.
- 6) Yonekura Y, Brill AB, Som P, Yamamoto K, Srivastava SC, Iwai J, Elmaleh DR, Livni E, Strauss HW, Goodman MM: Regional myocardial substrate uptake in hypertensive rats: A quantitative autoradiographic measurement. *Science* **227**: 1494-1496, 1985.
- 7) Osorio JC, Stanley WC, Linke A, Castellari M, Diep QN, Panchal AR, Hintze AH, Lopaschuk GD, Recchia FA: Impaired Myocardial Fatty Acid Oxidation and Reduced Protein Expression of Retinoid X Receptor- α in Pacing-Induced Heart Failure. *Circulation* **106**: 606-612, 2002.
- 8) Kelly DP, Strauss AW: Inherited cardiomyopathies. *New Engl J Med* **330**: 913-919, 1994.
- 9) Chiu HC, Kovacs A, Ford DA, Hsu FF, Garcia R, Herrero P, Saffitz JE, Schaffer JE: A novel mouse model of lipotoxic cardiomyopathy. *J Clin Invest* **107**: 813-822, 2001.
- 10) Kropp J, Eisenhut M, Ambrose KR, Knapp FF Jr, Franke WG: Pharmacokinetics and metabolism of the methyl-branched fatty acid (BMIPP) in animals and humans. *J Nucl Med* **40**: 1484-1491, 1999.
- 11) Tadamura E, Kudoh T, Hattori N, Inubushi M, Magata Y, Konishi J, Matsumori A, Nohara R, Sasayama S, Yoshiyoshi M, Tamaki N: Impairment of BMIPP uptake precedes abnormalities in oxygen and glucose metabolism in hypertrophic cardiomyopathy. *J Nucl Med* **39**: 390-396, 1998.
- 12) Watanabe K, Fujii H, Takahashi T, Kodama M, Aizawa Y, Ohta Y, Ono T, Hasegawa G, Naito M, Nakajima T, Kamijo Y, Gonzalez FJ, Aoyama T: Constitutive regulation of cardiac fatty acid metabolism through peroxisome proliferator-activated receptor α associated with age-dependent cardiac toxicity. *J Biol Chem* **275**: 22293-22299, 2000.
- 13) Chouraqi P, Maddahi J, Henkin R, Karesh SM, Galie E, Berman DS: Comparison of myocardial imaging with iodine-123-iodophenyl-9-methylpentadecanoic acid and thallium-201-chloride for assessment of patients with exercise-induced myocardial ischemia. *J Nucl Med* **32**: 447-452, 1991.
- 14) Hashimoto J, Kubo A, Iwasaki R, Fujii H, Kunieda E, Iwanaga S, Mitamura H, Ogawa S: Scintigraphic evaluation of myocardial ischemia using a new fatty acid analogue: iodine-123-labelled 15-(p-iodophenyl)-9-(R, S)-methylpentadecanoic acid (9MPA). *Eur J Nucl Med* **26**: 887-893, 1999.
- 15) Kawai C: From myocarditis to cardiomyopathy: mechanisms of inflammation and cell death: learning from the past for the future. *Circulation* **99**: 1091-1100, 1999.
- 16) Kodama M, Matsumoto Y, Fujiwara M, Masani F, Izumi T, Shibata A: A novel experimental model of giant cell myocarditis induced in rats by immunization with cardiac myosin fraction. *Clin Immunol Immunopathol* **57**: 250-262, 1990.
- 17) Kodama M, Hanawa H, Saeki M, Hosono H, Inomata T, Suzuki K, Shibata A: Rat dilated cardiomyopathy after autoimmune giant cell myocarditis. *Circ Res* **75**: 278-284, 1994.
- 18) The SOLVD Investigators. Effect of enalapril on survival in patients with reduced left ventricular ejection fractions and congestive heart failure. *New Engl J Med* **325**: 293-302, 1991.
- 19) The CONSENSUS Trial Study Group. Effects of enalapril on mortality in severe congestive heart failure: results of the Cooperative North Scandinavian Enalapril Survival Study (CONSENSUS). *New Engl J Med* **316**: 1429-1935, 1987.
- 20) Kashimura T, Hayashi M, Kodama M, Nakazawa M, Abe A, Yoshida T, Tachikawa H, Hanawa H,

- Kato K, Watanabe K, Aizawa Y: Effects of imidapril and TA-606 on rat dilated cardiomyopathy after myocarditis. *Jpn Heart J* **44**: 735-744, 2003.
- 21) Tachikawa H, Kodama M, Hui L, Kashimura T, Hayashi M, Nakazawa M, Abe A, Yoshida T, Kato K, Hanawa H, Watanabe K, Aizawa Y: Angiotensin II type 1 receptor blocker, valsartan, prevented cardiac fibrosis in rat cardiomyopathy after autoimmune myocarditis. *J Cardiovasc Pharmacol* **41** (Suppl. 1): S105-S110, 2003.
- 22) Folch G, Lees M, Stanley GHS: A simple method for isolation and purification of total lipids from animal tissues. *J Biol Chem* **226**: 497-509, 1956.
- 23) Opie LH, Owen P: Assessment of mitochondrial free NAD⁺/NADH ratios and oxaloacetate concentrations during increased mechanical work in isolated perfused rat heart during production or uptake of ketone bodies. *Biochem J* **148**: 403-415, 1975.
- 24) Yamauchi S, Takeishi Y, Minamihaba O, Arimoto T, Hirono O, Takahashi H, Miyamoto T, Nitobe J, Nozaki N, Tachibana H, Watanabe T, Fukui A, Kubota I: Angiotensin-converting enzyme inhibition improves cardiac fatty acid metabolism in patients with congestive heart failure. *Nucl Med Commun* **24**: 901-906, 2003.
- 25) Hambye AS, Dobbeleir AA, Vervaeke AM, Van den Heuvel PA, Franken PR: BMIPP imaging to improve the value of sestamibi scintigraphy for predicting functional outcome in severe chronic ischemic left ventricular dysfunction. *J Nucl Med* **40**: 1468-1476, 1999.
- 26) Uehara M, Kishikawa H, Isami S, Kisanuki K, Ohkubo Y, Miyamura N, Miyata T, Yano T, Shichiri M: Effect on insulin sensitivity of angiotensin converting enzyme inhibitors with or without sulphydryl group: Bradykinin may improve insulin resistance in dogs and humans. *Diabetologia* **37**: 300-307, 1994.
- 27) Henriksen EJ, Jacob S, Kinnick TR, Youngblood EB, Schmit MB, Dietze GJ: ACE inhibition and glucose transport in insulin resistant muscle: Roles of bradykinin and nitric oxide. *Am J Physiol* **277**: R332-R336, 1999.
- 28) Damas J, Bourdon V, Lefebvre P: Insulin sensitivity, clearance and release in kininogen-deficient rats. *Exp Physiol* **84**: 549-557, 1999.
- 29) Cahova M, Vavrinkova H, Tutterova M, Meschisvili E, Kazdova L: Captopril enhanced insulin-stimulated glycogen synthesis in skeletal muscle but not fatty acid synthesis in adipose tissue of hereditary hypertriglyceridemic rats. *Metabolism* **52**: 1406-1412, 2003.
- 30) Paul K, Ball NA, Dorn GW, Walsh RA: Left ventricular stretch stimulates angiotensin II-mediated phosphatidylinositol hydrolysis and protein kinase C ϵ isoforms translocation in adult guinea pig hearts. *Circ Res* **81**: 643-650, 1997.
- 31) Dal Ponte D, Fogt DL, Jacob S, Henriksen EJ: Interactions of captopril and verapamil on glucose tolerance and insulin action in an animal model of insulin resistance. *Metabolism* **47**: 982-987, 1998.
- 32) Petersen KF, Shulman G: Pathogenesis of skeletal muscle insulin resistance in type 2 diabetes mellitus. *Am J Cardiol* **90**: 11G-18G, 2002.
- 33) Schulmann G: Cellular mechanisms of insulin resistance. *J Clin Invest* **106**: 171-176, 2000.
- 34) Paolisso G, Gambardella A, Galzerano D, D'Amore A, Rubino P, Verza M, Teasuro P, Varricchio M, D'Onofrio F: Total body and myocardial substrate oxidation in congestive heart failure. *Metabolism* **43**: 174-179, 1994.
- 35) Paternostro G, Camici PG, Lammerstma AA, Marinho N, Baliga RR, Kooner JS, Radda GK, Ferrannini E: Cardiac and skeletal muscle insulin resistance in patients with coronary heart disease: a study with positron emission tomography. *J Clin Invest* **98**: 2094-2099, 1996.
- 36) Taylor M, Wallhaus TR, Degrado TR, Russell DC, Stanko P, Nickles RJ, Stone CK: An evaluation of myocardial fatty acid and glucose uptake using PET with [F-18]fluoro-6-thiaheptadecanoic acid and [F-18]FDG in patients with congestive heart failure. *J Nucl Med* **42**: 55-62, 2001.